

FEATURES

- CE ROHS certificate approval.
- Input voltage from 90 to 280 VAC .
- Used with 11.1V 3000mAH lithium Ion battery pack.
- Perfectly compatible with both DC LED loads and AC LED external driver.
- Emergency operation of LED light source and luminaries.
in extreme temperature from -10°C to 50°C(14°F to 122°F).
- 2 years Warranty.
- Accessory: test switch and charge indicator.



CHARACTERISTICS

Item	Data
Model name	DF168H
Input voltage	AC90-280V/50-60HZ
Charging current	200 mA Max
Rated power	24W Max
Emergency output power	18W (24W Max)
Output voltage	90-280VDC
Output current	800 mA Max
Power factor	≥0.9
Battery	LIR 11.1V 3000mAH
Charging time	24 hours
Duration time	90 minutes
Efficiency	≥0.7
Design life time	5 years
Warranty	2 years
Charging cycles	500-2000
Abnormal protection	Over load ,no-load ,open circuit , Short-circuit ,overcharge , Over-discharge protection
Model size	L168 x W38 x H28 [mm] L6.61 x W1.50 x H1.10 [inch]
Operation temperature	-10 °C to 50 °C (14°F to 122°F)

INVERTER DIMENSIONS

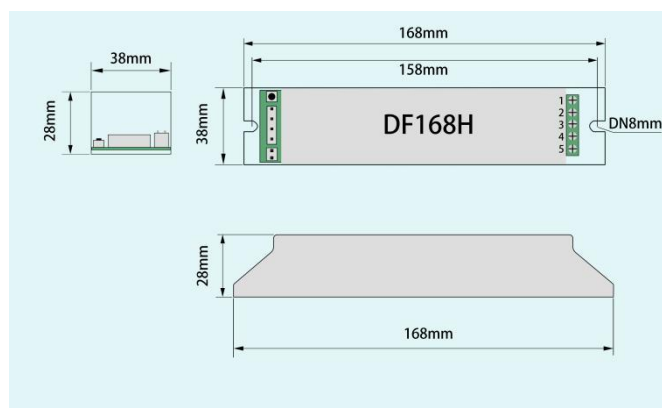

Inverter	L1 mm[inch]	L2 mm[inch]	W mm[inch]	H mm[inch]
DF168T	168[6.61]	158[6.22]	38[1.50]	28[1.10]

BATTERY DIMENSIONS

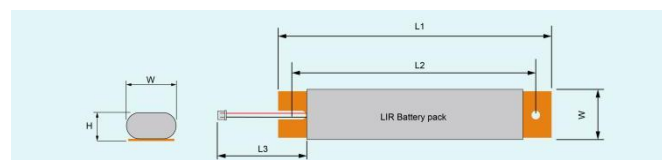

Battery spec	L1 mm[inch]	L2 mm[inch]	L3 mm[inch]	W mm[inch]	H mm[inch]
LIR11.1V3000mAH	160[6.30]	140[5.51]	170[6.69]	38[1.50]	22[0.87]

APPLICATIONS

- 1.The product can operate with most LED lamps. For normal of LED , need an extra LED driver.
- 2.The emergency power and time are customized.
- 3.Slim aluminium housing.
- 4.Not intended for use in luminaries for high-risk task area lighting.
- 5.IP20 protection, relies on end-product enclosure for protection against accidental contact-live parts and achieve IP65 rating.
- 6.Suitable for indoor, dry and damp applications.

WIRING INSTRUCTIONS

- 1—— Connect Live Wire TL+ switch line S.
- 2—— Connect the null line N.
- 3 4—— Connect LED driver and LED light source.
- 5—— Connect switch line S. The other side of switch line S enter the fire wire 1 port. Switch line S and Live wire must be consistent with the phase.Wall switch S only control the main electrical lighting and will not affect emergency lighting.

WIRING DIAGRAMS

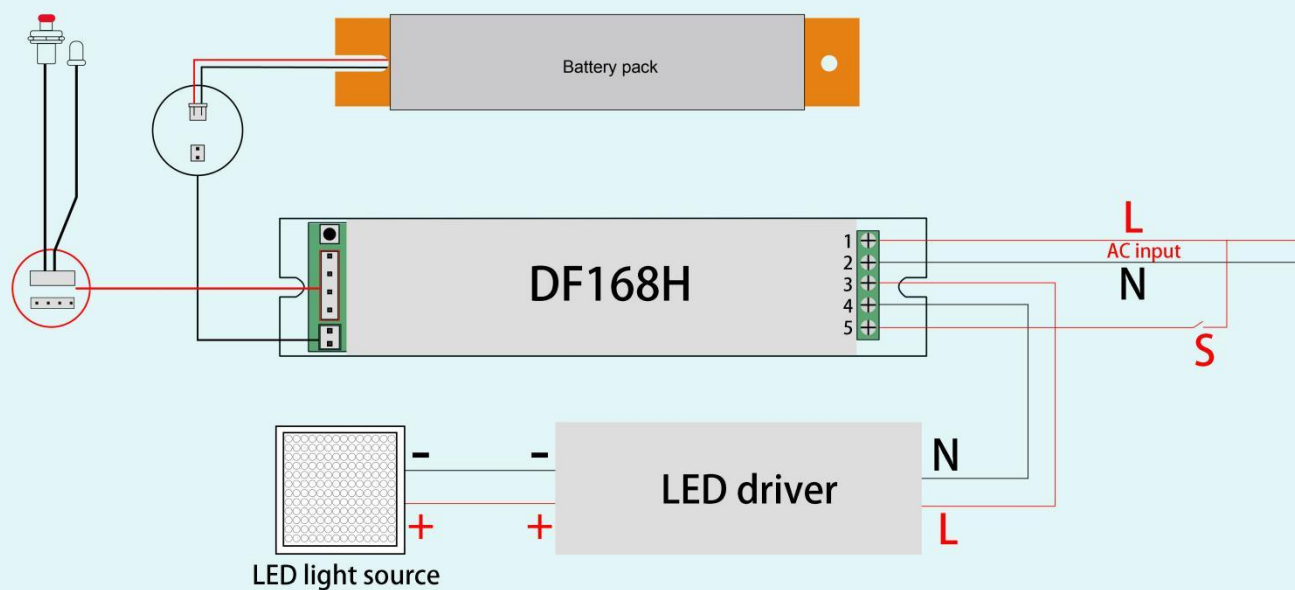

NOTICE

- (1) This product should be installed by trained electricians. To prevent electric shock, switch off the mains power supply until installation is complete and AC power is supplied to this product.
- (2) Main power line: Live wire TL and null line N, connect to main power line directly. No switch can be allowed when emergency lighting. The law forbids the switch control emergency circuit.
- (3) The wall switch only controls the main power, no function on emergency lighting. The Switch live wire SL and charging live wire TL should be in the same phase.
- (4) To reduce the risk of electrical shock, switch off the mains power supply before servicing.
- (5) The use of accessories equipment not recommended by the manufacturer may cause an unsafe condition.
- (6) Emergency lighting condition, three-color light is all out.
- (7) In order to avoid emergency lighting function failure, you should connect the led lamp and the emergency power pack before use.
- (8) The environment temperature of the emergency power pack ranges from -10 °C to 50°C. High-temperature aging test is forbidden.
- (9) Do not use this product for other than intended use.
- (10) Frequently test is prohibited. Each test interval is not less than one minute.
- (11) As this product contains batteries, please be sure to store it in an indoor environment between 0 °C to 50°C . It must be fully charged and discharged every 6 months from the date of purchase until it is officially put into use, then recharged 30-50% and stored for another and so on. If the battery is not used for more than 6 months, it may cause excessive self-discharge of the battery, and the resulting reduction of battery capacity is irreversible. For products with separate battery and emergency module, please disconnect the connection between battery and module for storage. Due to its chemical properties, it is a normal situation for the battery capacity to decline naturally during use. Users should take this into account when choosing products.
- (12) Ensure product compatibility before final installation. Make sure the polarity is correct when connecting the batteries. Wiring should be strictly in accordance with the wiring diagram, wiring errors will damage the product. A case of safety accident or product failure caused by users' illegal operation does not belong to the scope of customer complaint acceptance, compensation or product quality assurance.
- (13) Any problem, contact the manufacturer or supplier please.